



WIDER

WIDER1A × WIDER2A

This is The Newest Spray Gun

⚠ Safety Precautions

■ Usage

1. Before operating the product, please read and follow the instruction manual carefully, and operate it properly.
2. Never alter or modify the product. It will not be able to provide adequate performance, and damage could result.

■ Miscellaneous

1. The performance specifications in this catalog were obtained using our test paint. Values will depend on the paint used and environmental conditions.

- The products in this catalog are intended for use in Japan. Therefore, before purchasing them in Japan for export, check that they comply with your country's domestic legal regulations and safety standards in the export destination country.
- Specifications stated in this catalog are subject to change without notice, for purpose of improvement.
- Photos and other content may not match some products, due to specification changes, etc.

■ Your contact

ANEST IWATA Corporation

3176, Shinyoshida-cho, Kohoku-ku, Yokohama 223-8501, Japan
 Customer Contact: 0800-100-1926 (toll free in Japan)
 *Available to mobile phone.
 Website: <http://www.anest-iwata.co.jp/english>



Dependable Quality and Repeatability From “W” to “WIDER” —the New Model Has Arrived

The key points in industrial coating products are quality and repeatability. We have always created the ideal spray guns, adapted to diverse applications and evolving paints. For 23 years since the debut of the WA-200, and 14 years since the WA-101, we have been accumulating experience and expertise that we have now distilled into this new WIDER model. We have refined the initially simplistic appearance, and improved ease of maintenance, to create this new model.



FEATURE 01 MAINTENANCE

New Models Make Maintenance Easier

Every adjustment knob is tapered with deeper grooves to facilitate fine adjustments. Each nipple has an entry guide for easier hose connection.

Air Cap Set

- We changed the thread pitch from 1.0 mm to 1.5 mm, so that the cap is easier to remove and reattach.
- The design absolutely minimizes air leakage from the air cap cover, and a new material choice delivers superior solvent resistance.

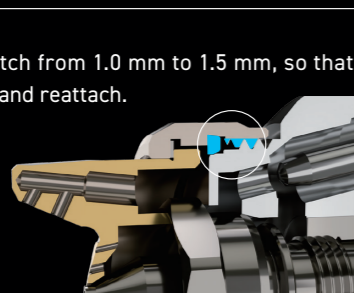

Air Valve Seat Set

The previous model valve seat could only be removed with special tools, but that of the new model can be removed with a 14-mm box wrench.



Previous model WIDER

FEATURE 02 FEEL

Linear Response Pattern Adj. set

The previous pattern adj. set reached around 45% of full pattern width with 1 turn, around 80% with 1.5 turns, and almost 100% or nearly fully open with 2 turns. Our newly-developed pattern adj. set now provides around 35% with 1 turn, around 50% with 1.5 turns, and around 70% with 2 turns. This linear response to adjustment is intuitively easier to operate.

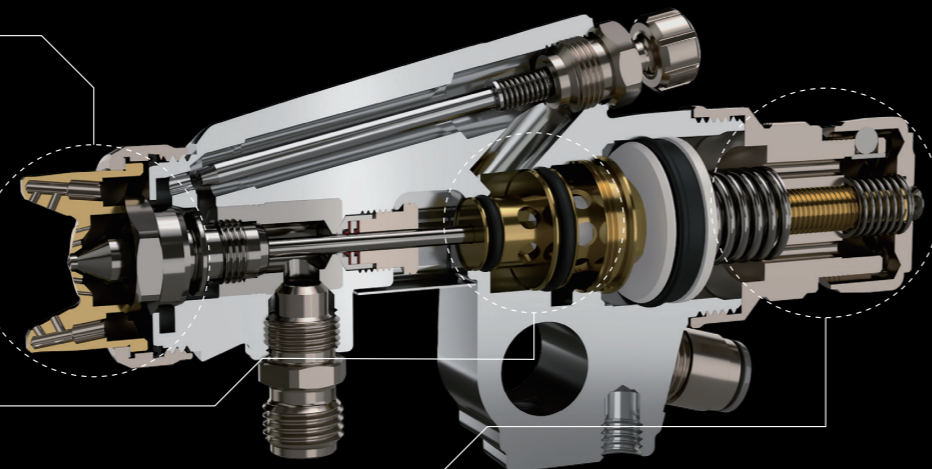
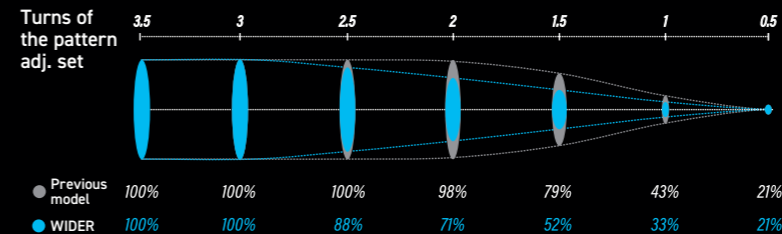

Fluid Adj. set

The old model adjuster had to be removed with a 32-mm box wrench, but that of the new model can be removed without tools.



Previous model WIDER

Part Compatibility

The illustration on the right shows parts which are incompatible between the previous WA-101 and the WIDER1A (between the previous WA-200 and the WIDER2A).

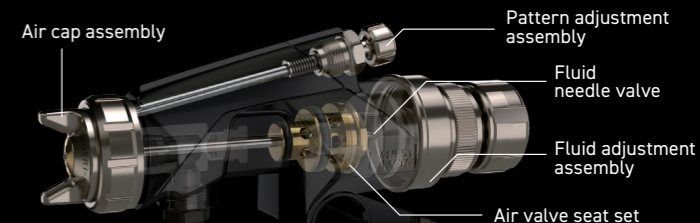

Fluid Needle Packing Set

The structure and material of the fluid needle packing has been proven for over 20 years, and are used on nearly all ANEST IWATA hand or automatic spray gun products. The packing part that stops paint flow is made of a special composite material made from fluorine resin (red) and rubber (black), bonded together. The fluorine resin holds back the paint, while the rubber ensures durability. There are two packing layers, so that even if the first starts to leak, the second will still stop the paint. We have made repeated minor changes to the materials, to achieve further durability.

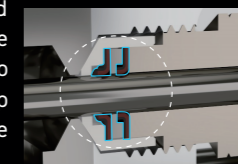

Air Hose Connection

WIDER 1A/2A are equipped with one-touch couplings as standard (atomizing air: Φ 8 mm, operating air: Φ 6 mm). Therefore, if you are still using our conventional joints, you will need to replace them with the air nipples provided.



System Diagram

The WIDER 1A/2A Series, which use built-in air valves, are able to spray if one three-way solenoid valve is available. You can leave the atomizing air connected, so you can spray without having to set up any complicated system. Pattern adjustment is done by manually turning the pattern adjustment knob, so remote operation is not possible.

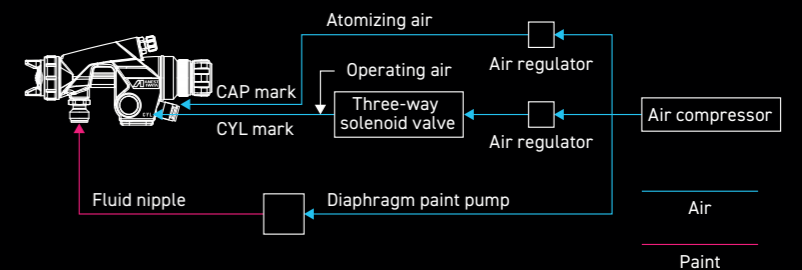

	Previous model	Model	Fluid nozzle diameter Φ (mm)	Recommended spraying conditions			Air consumption (L/min)	Pattern width (mm)	Air Cap	Spray pattern	Connection	Weight (g)		
				Atomizing air pressure* (MPa)	Fluid output (mL/min)	Spraying distance (mm)								
Small	WA-101-082P	WIDER1A-08E2P	0.8	0.29	150	200	270	190	WIDER1-E2P	Round to flat pattern	[Air] Atomizing air (CAP) Φ 8 Operating air (CYL) Φ 6	400		
	WA-101-102P	WIDER1A-10E2P	1.0		200		270	220						
	WA-101-101P	WIDER1A-10E1	1.0		100		90	140					WIDER1-E1	
	WA-101-132P	WIDER1A-13H2	1.3		250		260	230					WIDER1-H2	
	WA-101-152P	WIDER1A-15H2	1.5		270		260	255					[Fluid] G1/4 male	
	WA-101-05R	WIDER1A-05R	0.5		20		40	35					WIDER1-05R	Round pattern
Large	WA-200-122P	WIDER2A-12G2P	1.2	0.29	500	250	530	400	WIDER2-G2P	Round to flat pattern	[Air] Atomizing air (CAP) Φ 8 Operating air (CYL) Φ 6	420		
	WA-200-152P	WIDER2A-15K2	1.5		270		330	340					WIDER2-K2	
	WA-200-202P	WIDER2A-20R2	2.0		400		360	320					WIDER2-R2	
	WA-200-251P	WIDER2A-25W1	2.5		500		360	330					WIDER2-W1	[Fluid] G3/8 male

* Spraying air pressure is the spray gun inlet pressure when the piston is withdrawn to allow air flow.

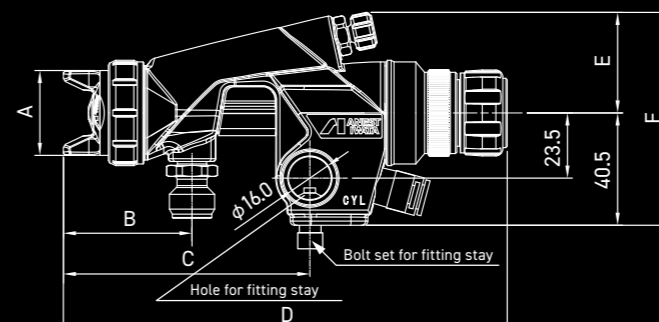

Mounting dimensions (mm)

Model	A	B	C	D Fully closed - Fully open	E	F
WIDER1A	27.0	43.5	85.5	158.5	162.5	36.0
WIDER1A-R	27.0	36.5	79.0	151.5	156.0	35.0
WIDER2A	30.5	46.5	89.0	160.0	165.5	37.0

* Dimension C is the same as on the previous WA-101 and WA-200, so you can continue usage even after replacement.